

Integrity · Innovation · Quality

誠信 · 創新 · 品質

搓牙機 專業製造

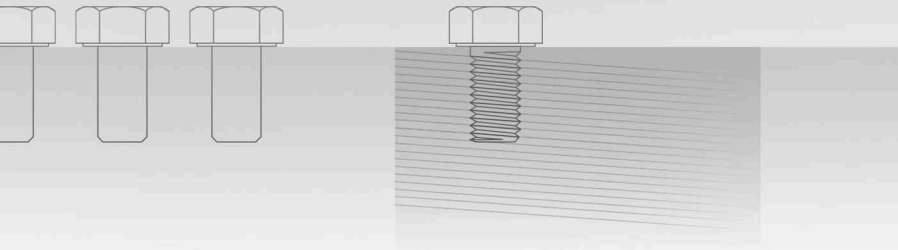

 銓益盛機械有限公司
CHUAN YI SHENG MACHINERY CO., LTD.

ADD / No. 113, Ln. 96, Minquan Rd., Luzhu Dist., Kaohsiung City 821, Taiwan (R.O.C.)

821 高雄市路竹區民權路 96 巷 113 號

TEL / +886-7-696-0699 FAX / +886-7-696-1068

E-mail / vulauu@yahoo.com.tw · cys.machine@msa.hinet.net

URL / <http://www.cys-machinery.com.tw>

BEST PROFESSIONAL TEAM
MEET YOUR NEEDS

搓牙機 專業製造



經營理念 02 Business Philosophy

機型特色 03 Machine features

產品寫真 04 Thread Rolling Machine

創新設計 08 Innovation Design

牙板座	Diagram of Thread Rolling Die Holder
送料機構	Diagram of Feeder Mechanism
曲柄機構	Diagram of Crank Mechanism
擺臂機構	Diagram of Swing Arm
螺桿刻度環	Diagram of Screw Scale Ring
檢知座	Diagram of Rotary Detection Holder
軌道座	Diagram of Rail Holder
軌道蓋	Diagram of Rail Cover
電動升降門	Diagram of Electric Lift Door
滑軌式搓牙機	Diagram of Slide-Type Thread Rolling Machine

CONTENTS

Accessories 13 選購配件

Thread Rolling Machine Checker	檢測機
LED Work Lamp	LED 工作燈
Disk Brake	煞車器
Hoppr	儲料斗
Turbines Shaker	振盪器
Conveyor/Transporter	輸送機

Product Spec 15 產品規格表

MEMO 16 筆記欄

經營理念 Business Philosophy

銓益盛機械位於高雄市路竹區，以生產螺絲搓牙機及螺絲周邊機械為主要的營業項目，以 **CYS** 為銷售品牌，並整合相關產業，提供客戶整廠輸出的諮詢服務，秉持『誠信·創新·品質』的經營理念，帶領年輕的團隊穩步向前邁進，時至今日已研發多種機型可供選購。

螺絲產業競爭激烈，沒有進步就會被潮流淹沒，為此本公司毅然投入螺絲機械的生產，提供品質優良的機械，讓客戶獲取最大利潤是我們的目標，因為我們深信與客戶共同成長，方能奠定銓益盛永續經營的基礎。

CHUAN YI SHENG MACHINERY the headquarters is located in Luzhu District, Kaohsiung City. This Company's main business lines are the production of various types of thread rolling machine and auxiliary machinery, and **CYS** is the brand of marketing; in addition, we integrated related industries to provide clients with consulting service of turnkey plant export. This Company is upholding the business philosophy of "Integrity•Innovation•Quality" to lead young work teams to stride forward steadily. Up until now, we have developed various types of machine and are available for selection and purchase.

Competition is very intensive in Screw industry, one will be eliminated from the trend of this industry if there's no progress. For this reason, this Company has been determinedly put into the production of screw machinery. Our goal is to provide our clients with quality machinery that allow them to make the maximum profits, because we do believe that a mutual development with clients is the foundation of establishing the sustainable operation for **CYS**.

JC SERIES

JC 系列高速自動輓牙機採用 90 度送料，此系列有送料穩定、可無頭送料、高精密度及容易維護等特點。

JC series High Speed Automatic Thread Rolling Machine uses 90 degrees feeding, this series is characterized by feeding stable, headless screw feed, high precision, and easy maintenance.

機型特色 Machine Features

SC SERIES

SC 系列高速自動輓牙機採用斜 30 度送料，此系列有進料時間短及送料速度快的特點。

SC series High Speed Automatic Thread Rolling Machine uses oblique 30 degrees feeding, this series is characterized by feeding time shorter, and feeding speed faster.

產品寫真

Thread Rolling Machine

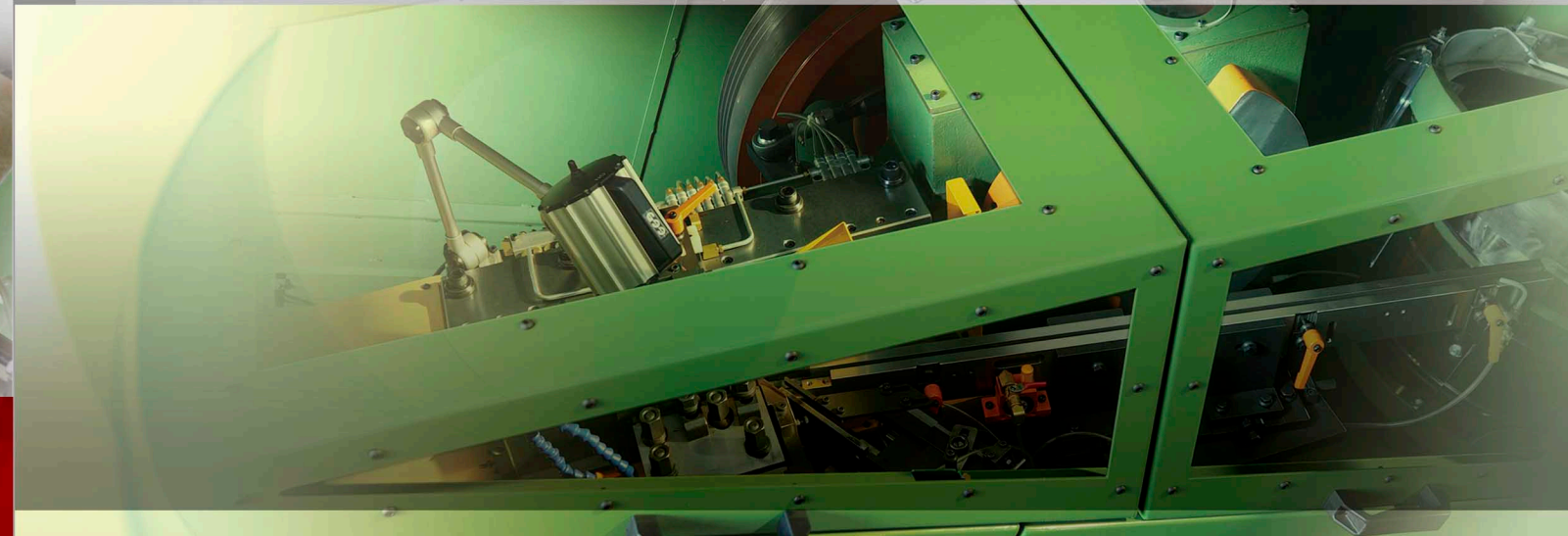

密封外罩搓牙機

Enclosure Covering Thread Rolling Machine



MODEL SC20

產品寫真

Thread Rolling Machine

MODEL JC06



MODEL JC08



密封外罩搓牙機 Enclosure Covering Thread Rolling Machine

▲ 密封外罩搓牙機 Enclosure Covering Thread Rolling Machine



MODEL JC08

Semi-Esclosure Covering Thread Rolling Machine 半密封外罩搓牙機 ▼

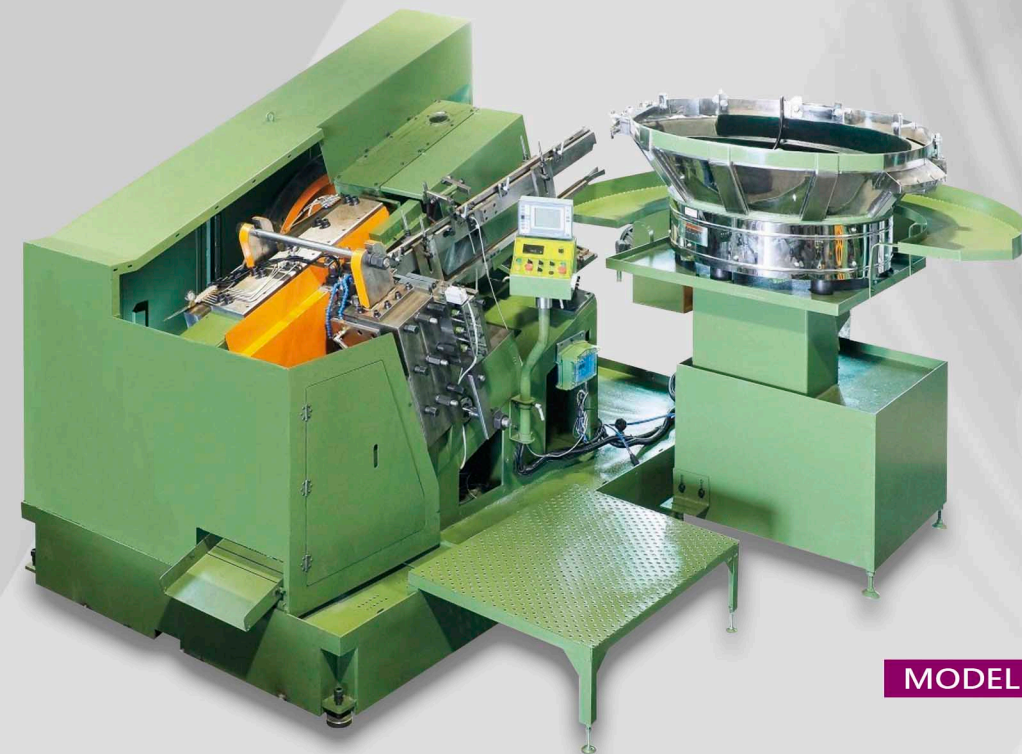

MODEL JC12

產品寫真

Thread Rolling Machine



MODEL JC06

創新設計

Innovation Design

牙板座 Diagram of Thread Rolling Die Holder

優點 /

- 增加固定位置，牙板座無鬆動的問題。
- 增加牙板座底墊片，降低日後維修成本。
- 增加牙板座後側墊片，更換容易且維修成本低。

Advantage /

- Add more fixative positions, there' s no loosen problem in thread rolling die holders.
- Add pad on thread rolling die holders to reduce the follow-up maintenance cost.
- Add pad on the rear side of thread rolling die holder to make more convenient replacement and low maintenance cost.

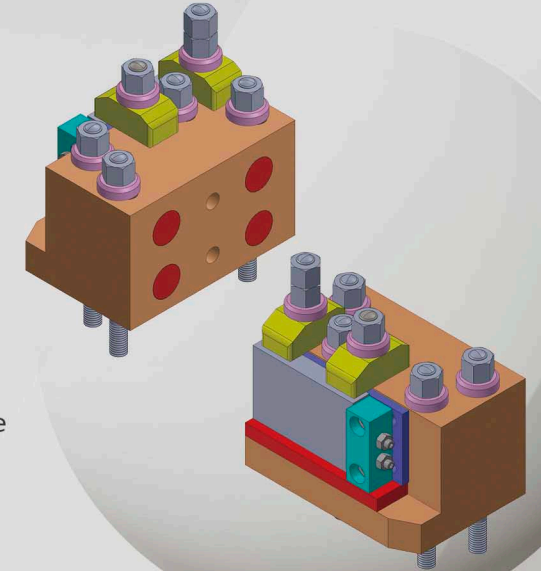

半密封外罩搓牙機

Semi-Esclosure Covering Thread Rolling Machine

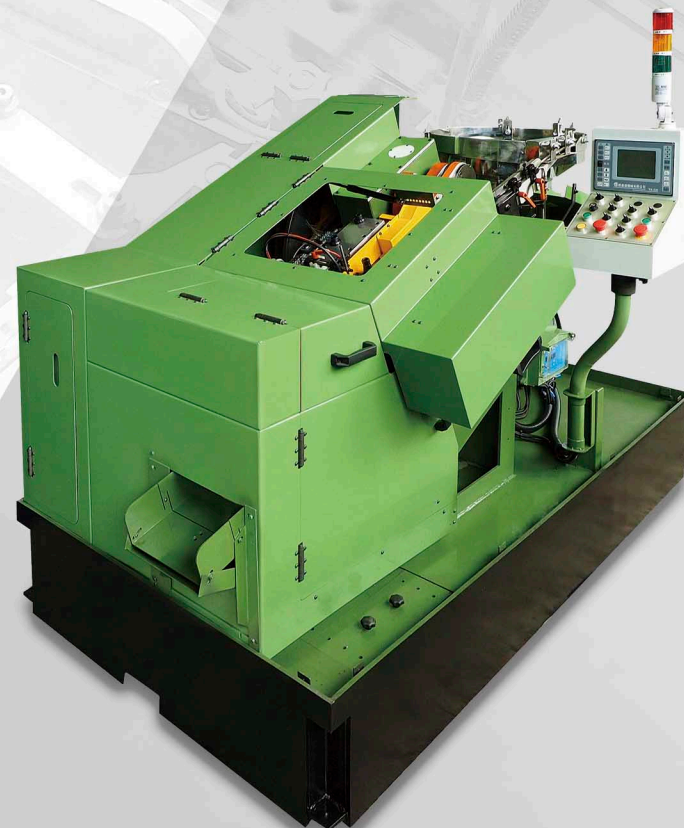

MODEL JC10

創新設計

Innovation Design

送料機構 Diagram of Feeder Mechanism

優點 /

- 增加推料片調整塊，結構强度高，送料精準。
- 耗材成本低，維修容易。

Advantage /

- Add the adjusting block and material-piling plate, high structural strength and precise material-feeding.
- Low cost of consumable material, easy maintenance.

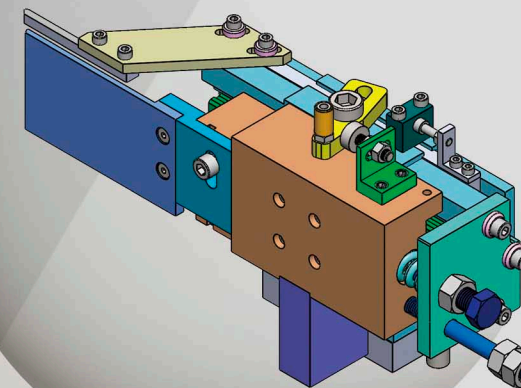

創新設計

Innovation Design

曲柄機構 Diagram of Crank Mechanism

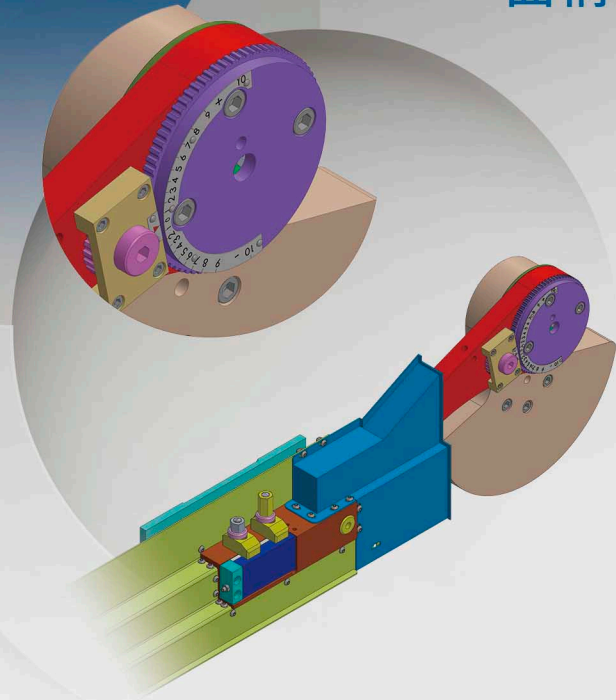

優點 /

- 用整塊鋼材加工成型，強度及使用年限均高。
- 精密可調式設計（附刻度指示），容易調整且準確度高。

Advantage /

- Made of steel and processed and formed, high strength and service life.
- Precise and adjustable design (with scale indication), easy adjustment and high precision.

螺桿刻度環 Diagram of Screw Scale Ring

優點 /

- 調整牙板座可依據刻度環指示，使移動距離數據化，達到精確的調校。

Advantage /

- The thread rolling die holders can be adjusted to the indication of the scale ring, the moving distance of the deformations. Achieve accurate calibration.

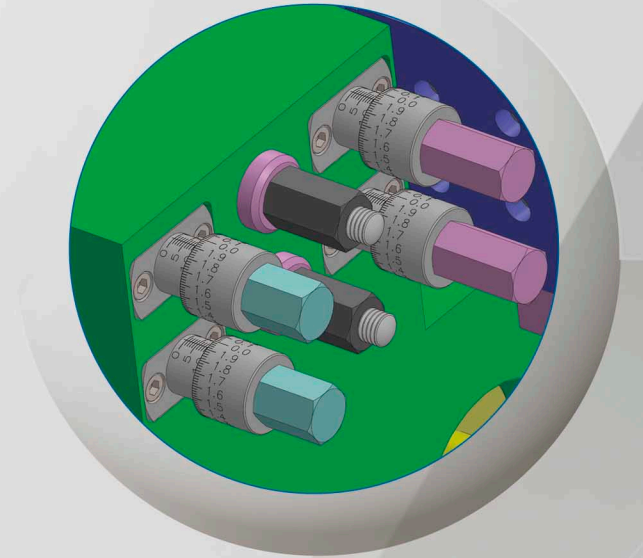

創新設計

Innovation Design

擺臂機構 Diagram of Swing Arm

優點 /

- 無凸輪式機構，使用壽命長且容易維修。

Advantage /

- Cam-less Mechanism, long use life and easy maintenance.

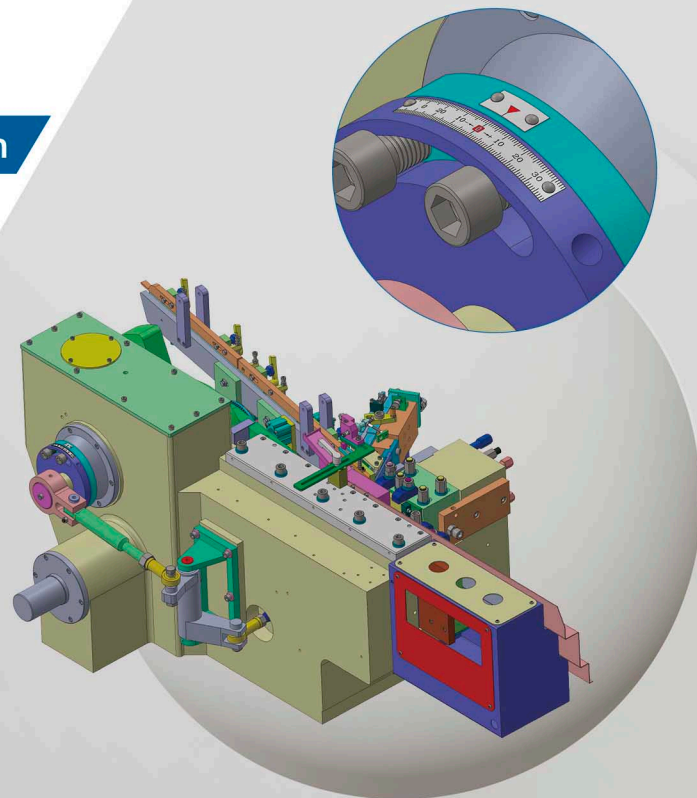

檢知座 Diagram of Rotary Detection Holder

優點 /

- 左圖為正常運作時。
- 需調校或維修時可將機構旋轉 90 度（如右圖），避免干涉。

Advantage /

- Normal operation (as shown in left).
- Rotate this mechanism 90 degrees when needing adjustment or maintenance (as shown in right) to avoid any interference.

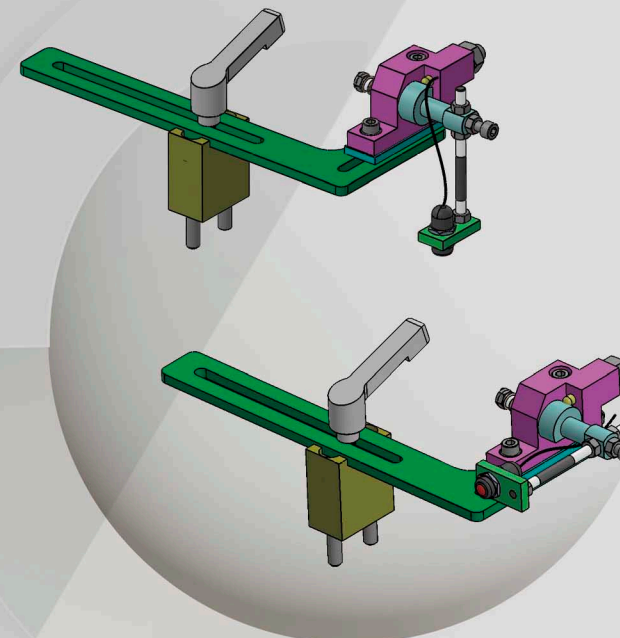

創新設計 Innovation Design

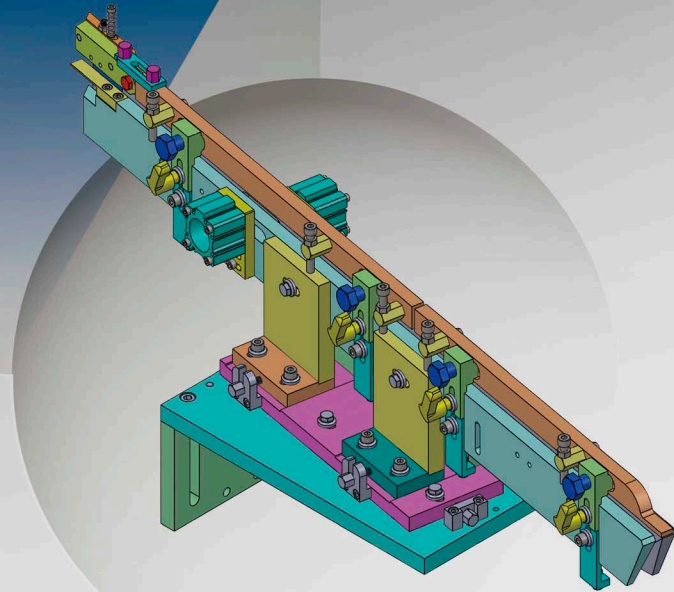

軌道座 Diagram of Rail Holder

優點 /

- 可依據實際需求做多個方向的調整，實用性高。

Advantage /

- Direction-adjustable according to demands, high practicability.

電動升降門 Diagram of Electric Lift Door

優點 /

- 用機構帶動檢視窗的開啟或閉合，兼具省時及省力的優點，便於查看機台內部狀況及調校。

Advantage /

- Mechanism drive inspection window opening or closing, both the advantages of saving time and labor-saving, easy to view machine status and internal adjustment.



創新設計 Innovation Design

軌道蓋 Diagram of Rail Cover

優點 /

- 改良式軌道蓋，增加接觸面積，避免浮頭，提昇良率。

Advantage /

- Refined rail cover with increased contact surface to avoid from occurring floating head to greatly improve the yield rate.

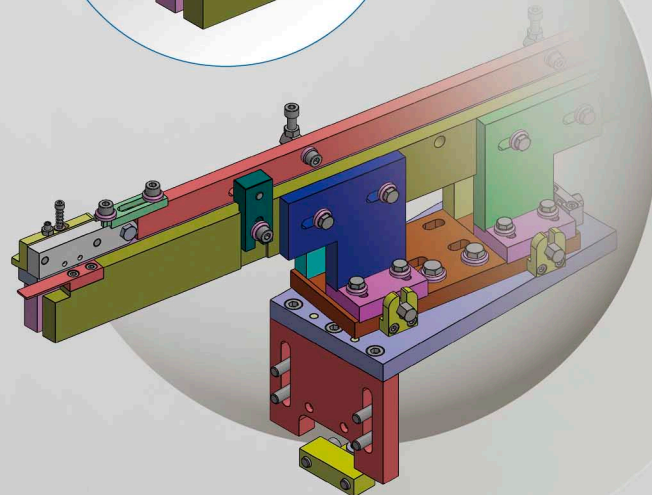
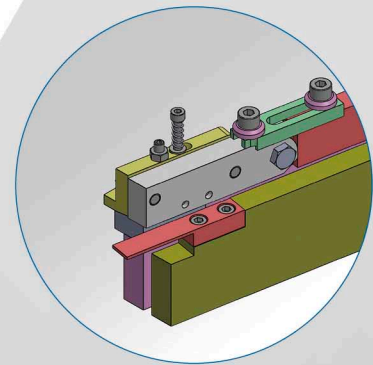

滑軌式搓牙機 Diagram of Slide-Type Thread Rolling Machine

優點 /

- 使用進口精密滑軌，機械可超高速穩定運轉。
- 使用黃油潤滑，保養容易且成本低廉。
- 無鋼板及銅板的設計，維修簡單迅速。

Advantage /

- Use imported precise slide rail, it can be operated steadily at ultrahigh speed.
- Use grease to lubricate, easy maintenance and low cost.
- Steel/Copper-plate-Free design, easy and fast maintenance.



選購配件

Accessories

檢測機 Thread Rolling Machine Checker



- 可檢測長短料、拖牙、浮頭、頭部異常等各種異常狀況。
- 不良品發生自行停機警示，可保護設備及降低產品不良率。
- 採全檢方式，功能全自動，可達到節省人力的目地。
- Can check abnormalities, such as material defect, drag, floating head and head abnormality, etc.
- Can stop and have warning automatically in case of defective products that can protect relative equipment and reduce the product defect rate.
- Use all-detection method and auto function to reach the goal of economizing manpower.

儲料斗 Hopper



- 可與振動盤連動，避免因人為疏忽造成停機。
- 可大幅節省人力及提高效率。
- Interlock with vibrating plate to avoid man-made errors to stop the machine.
- Can greatly save manpower and increase efficiency.

LED 工作燈 LED Work Lamp

- 高功率防爆型，安全無虞。
- 高亮度，可補足工作環境的不足照明
- High-power and Explosion-proof type, safe and secure.
- High luminance can make up the deficient lighting in work environment.



煞車器 Disk Brake

- 遇突發狀況時可立即將機器停止，降低損害。
- 制動力佳，後續維修費用低。
- Promptly stop the machine in case of any emergency to reduce damage.
- Good braking ability, low follow-up maintenance fees.

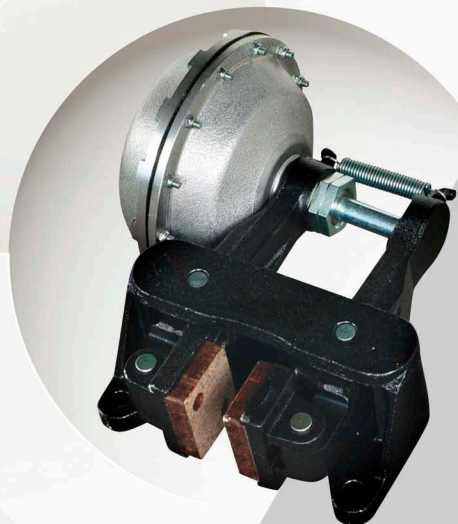

選購配件 Accessories

振盪器 Turbines Shaker

- 體積小，振盪能力高於同類型鋼珠式振盪器。
- 渦輪式設計，低噪音，無需保養且使用壽命長。
- 可使流料更加順暢。
- Compact size, shaking ability is higher than steel-ball shaker.
- Turbines design, low noise, no need of maintenance but having a long service life.
- Can make material flow more smoothly.



輸送機 Conveyor / Transporter

- 用於成品的運送，可節省額外人力。
- For the transportation of finished products, can save additional manpower.



